

Typical F9 Schematic Wiring Diagram – With Dynamic Braking  
 Plate 8845 – August, 1957

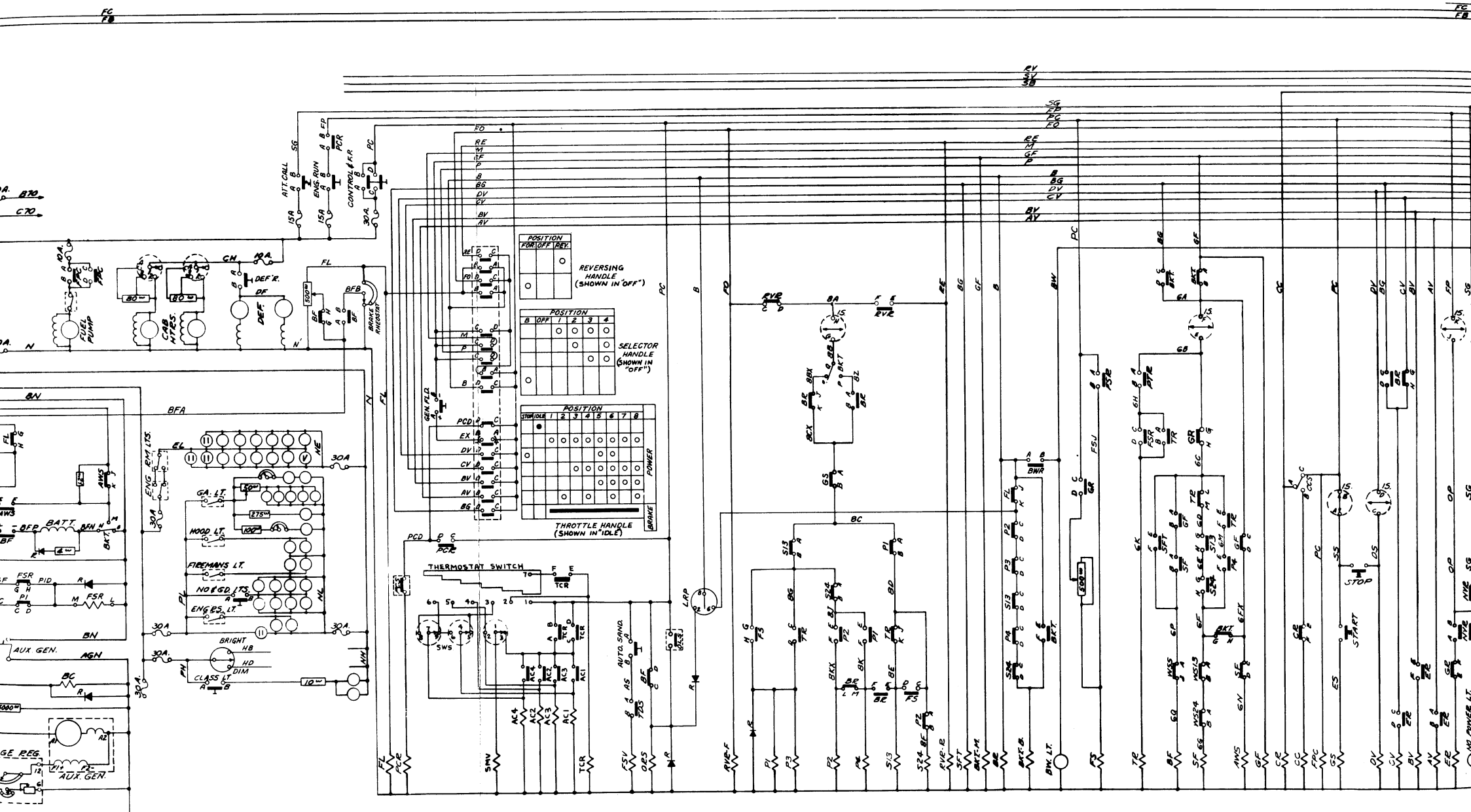

+

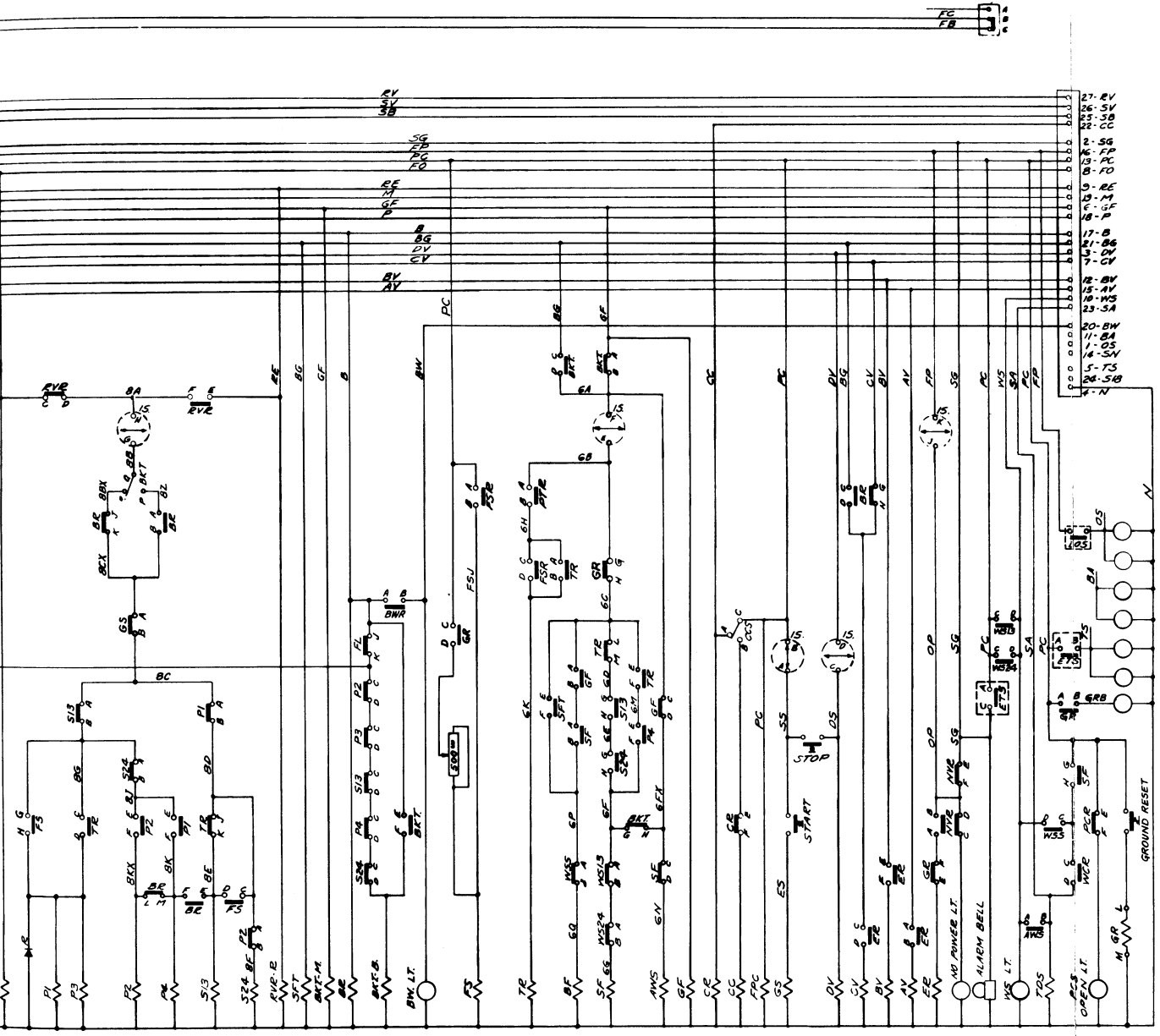

- 27- BV
- 26- SV
- 25- YB
- 24- CC
- 2- SG
- 16- FP
- 13- PL
- 8- FO
- 9- RF
- 10- M
- 11- GP
- 12- P
- 17- B
- 21- BA
- 3- DV
- 7- CV
- 12- BV
- 15- AV
- 18- MS
- 23- SA
- 20- BW
- 11- OS
- 14- SY
- 5- TS
- 24- SB
- 1- N

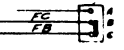

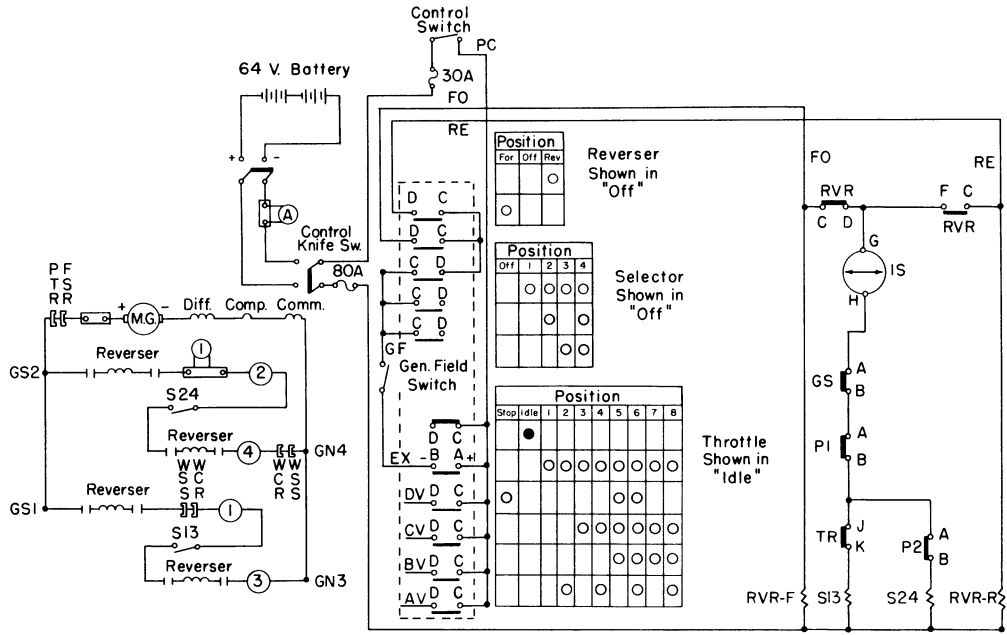

Locomotive Control Circuit  
Fig. 5-21



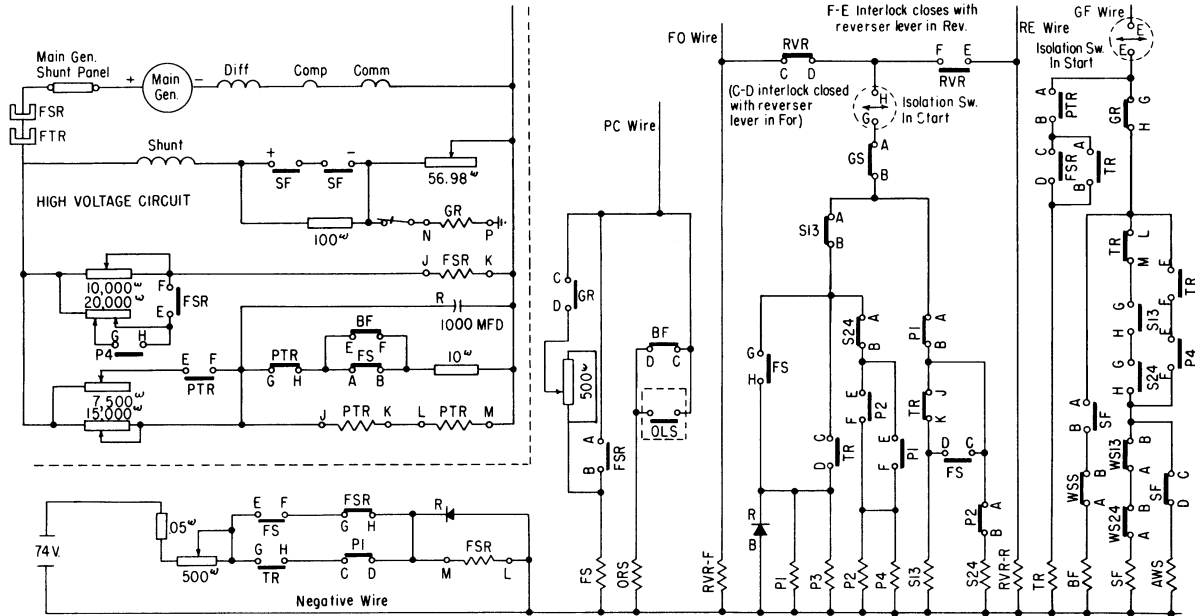

Transition Circuit  
Fig. 5-23

## LEGEND OF ELECTRICAL EQUIPMENT

The following list shows abbreviations identifying electrical equipment on the locomotive and/or the wiring diagrams. The diagram wire designations conform with the identification bands on the wires in the locomotive.

The diagram shows the contactors, switches and relays as if the engine was stopped and all manual switches open. It must be remembered that when the operating coil of a contactor becomes energized the contacts and interlocks associated with that contactor will then be in a position opposite to that shown in the wiring diagram.

A	Ammeter (Battery Ammeter)
AC1, 2, 3, 4	Radiator Cooling Fan Motor
	Contactors
AV, BV, CV, DV	Governor Control Solenoids
AWS	Auxiliary Wheel Slip Relay
BA	Boiler Alarm Light
BC	Battery Charging Contactor
BF	Battery Field Contactor
BKT	Dynamic Brake Transfer Switch
BKT-B	Dynamic Brake Transfer Magnet Valve - Brake
BKT-M	Dynamic Brake Transfer Magnet Valve - Motor
BR	Dynamic Brake Relay
BW	Brake Warning Indicating Light
BWR	Brake Warning Relay
C	Radiator Cooling Fan Motor Overload Switch
CC	Compressor Control Magnet Valve
CCS	Compressor Control Switch
CL	Class Light
CD	Traction Motor Lockout Switch
COMM	Commutating Field
COMP	Compensating Field
CR	Compressor Control Relay
DIFF	Differential Field
ER	Engine Relay (ER Relay)

ETS	Engine High Temperature Switch
FL	Field Loop Contactor
FMV or FSV	Forward Sanding Magnet Valve
FPC	Fuel Pump Contactor
FS	Traction Motor Field Shunting Contactor
FSR	Field Shunting Relay
GA	Gauge Light or Switch
GF	Generator Field Contactor
GR	Ground Relay
GS <sup>±</sup>	Generator Starting Contactor
I	Dynamic Brake and Load Indicating Meter
IS	Isolation Switch
LOS	Low Oil Pressure Switch
LRC	Load Regulator Contactor
LRS	Load Regulator Contactor Switch (In Governor)
MBL	Traction Motor Blower Motor
NV	"Alternator Failure" or "No Power" Signal Light
NVR	"No AC Voltage" Relay
OLS	Governor Overload Switch
ORS	Governor Over-Riding Solenoid
OS	Low Oil Signal Light
P	Parallel Power Contactor
PCR	Pneumatic Control Relay
PCS	Pneumatic Control Switch
PTR	Transition Relay
RBL	Radiator Cooling Fan Blower Motor
RCR	Reverse Current Relay
RMV or RSV	Reverse Sanding Magnet Valve
RVR	Reverser Switch
RVR-F or FOR	Forward Magnet Valve or Reverser Switch
RVR-R or REV	Reverse Magnet Valve or Reverser Switch
S	Series Power Contactor
SF	Shunt Field Contactor
SFT	Shunt Field Transfer Relay
SMV	Shutter Magnet Valve
SR	Signal Relay



<b>START</b>	<b>Starting Field</b>	—
<b>SWS</b>	<b>Summer-Winter Switch</b>	
<b>TCR</b>	<b>Temperature Control Relay</b>	—
<b>TDS</b>	<b>Time Delay Sanding Relay</b>	
<b>TR</b>	<b>Transition Relay</b>	
<b>TS</b>	<b>High Temperature (Hot Engine) Signal Light</b>	—
<b>WCR</b>	<b>Wheel Creep Relay</b>	
<b>WS</b>	<b>Wheel Slip Relay</b>	—
<b>WSA</b>	<b>Wheel Slip Auxiliary Relay</b>	
<b>WSS</b>	<b>Wheel Slip Series Relay</b>	—