

SPECIFICATIONS

GENERAL MOTORS 800 H.P. DIESEL-ELECTRIC SWITCHING LOCOMOTIVE



**ELECTRO - MOTIVE DIVISION
GENERAL MOTORS CORPORATION**

LA GRANGE, ILLINOIS, U. S. A.

**Specification 8020
April 2, 1950**

SW-8

**GENERAL MOTORS
800 H. P. DIESEL - ELECTRIC
SWITCHING LOCOMOTIVE**

INDEX

GENERAL INFORMATION AND IDENTIFICATION	Section 1
CONSTRUCTION	" 2
TRUCKS	" 3
POWER PLANT AND TRANSMISSION ENGINE, GENERATOR, COOLING AND LUBRICATING SYSTEMS	" 4
AIR BRAKES	" 5
EQUIPMENT	" 6
LOCOMOTIVE MODIFICATIONS	" 7
PAINTING	" 8
PERFORMANCE DATA	" 9
WARRANTY AND PATENTS	" 10
GENERAL OUTLINE	" 11

SECTION 1

General Information and Identification

GENERAL MOTORS
LOCOMOTIVES

Model	SW-8 (Type 0440) 800 H.P., 115 ton Switcher.	
General Dimensions	Track gauge.....	4' 8½"
	Length over coupler pulling faces.....	44' 5"
	Width over side sills.....	10' 0"
	Maximum height above rail.....	14' 6½"
	Platform height above rail.....	4' 7½"
	Height of cab floor above rail.....	6' 10⅝"
	Length of operator's cab.....	6' 6"
	Width of operator's cab.....	9' 11½"
	Height of power plant hood roof above rail.....	11' 9½"
	Width of power plant compartment.....	7' 0"
	Wheelbase—truck.....	8' 0"
	Truck centers.....	22' 0"
	Number of drivers.....	4 pairs
	Diameter of drivers.....	40"
	Size of journals.....	6½"x12"
	Minimum curve radius.....	100' 0"
Gear Ratio	Gear ratio.....	62:15
	Locomotive speed corresponding to maximum traction motor speed..	65 MPH.
Capacity	Starting T. E. at 25% adhesion (approximately).....	57,500 lbs.
	30% adhesion (approximately).....	69,000 lbs.
Weights (Approximately)	Total weight (fully loaded).....	230,000 lbs.
	Total weight (light).....	223,000 lbs.
	Weight on drivers.....	100%
	Journal load per driving axle.....	51,000 lbs.
Supplies (Approximately)	Fuel oil.....	600 gallons
	Cooling water.....	190 gallons
	Lubricating oil.....	145 gallons
	Sand.....	28 cu. ft.
Arrangement	The general arrangement and dimensions are shown on the outline drawing included at the rear of this specification.	
Safety Appliances	All steps, grab handles and other safety appliances cover EMD interpretation of Interstate Commerce Commission requirements.	

SECTION 2

Construction

GENERAL MOTORS
LOCOMOTIVES

Underframe The design and construction of the underframe provides a structure capable of withstanding the most severe buff and drag stresses. Integral with the underframe are the body bolsters, center plates, draft gear pockets, coupler strikers, side bearings, and jacking pads. Push pole pockets are provided at the ends of the side sills.

Center Plates Described under Section 3—Trucks.

Couplers Type "E" of standard length with $6\frac{1}{4}$ " x 8" shank and quadruple shear pin. Maximum swing of coupler is 12" each side of center. Centerline of coupler is 34" above rail.

Coupler Yokes Quadruple shear yoke with a section 6" x $1\frac{1}{4}$ ".

Coupler Carriers The coupler carrier is supported by the coupler pocket and held in place with a $1\frac{1}{8}$ " through-bolt. A wear plate is welded to the top face of the carrier to eliminate excessive wear.

Draft Gear National Malleable M-375 rubber draft gear.

Side Bearings Side bearing clearances of $\frac{1}{4}$ " on the front truck and $\frac{1}{2}$ " on the rear truck are provided.

Jacking Pads Four combination jacking pads and cable slings are provided, integral with the side sills opposite front and rear bolster.

Uncoupling Device Each end of the locomotive is provided with a three piece top operating device arranged to operate from either side of the locomotive.

Platform Steps Safe and suitable wide box steps are provided at each corner leading to the locomotive platform. They are recessed three step type.

Footboards Each end of the locomotive is provided with two footboards, mud guards, handrailings and grab irons.

Cab The single operator's cab is of fabricated steel construction providing maximum strength and durability. The main cab floor is elevated 26" above the top of the underframe, and the operator's platform is elevated an additional $8\frac{1}{2}$ " which, with the large cab windows and low hood, provides unobstructed vision in all directions. Side windows for operator and helper are the sliding, double sash type, and are fitted with latches. Front and rear doors are provided. A trap door is located in the cab floor which facilitates inspection of piping and electrical apparatus.

SECTION 2

Construction



- Windows** All windows and doors are glazed with safety plate glass. The rear windows are protected by guard bars.
- Doors** A main center door is located at the rear of the cab, and a door at the front left side permits access to the runway around the engine hood. Both doors are of fabricated steel construction.
- Door Locks** The main cab door is equipped with a Yale lock, and the front door is fitted with an inside latch.
- Insulation** The ceiling and walls of the cab are lined with a sound-deadening insulating material.
- Cab Floor** The floor is built of 1" tongue and groove No. 1 maple flooring screwed to steel supports.
- Battery Box** An all steel box is mounted outside on the platform at the rear of the cab. Construction incorporates proper insulation, supports, ventilation, and drainage. Batteries are easily accessible by means of hinged covers on the boxes.
- Hood** The power plant compartment has been designed to a minimum height and width to provide unobstructed vision from within the cab, as well as a runway around the hood. The sides are in effect made up of continuous double doors which permit complete accessibility to the power plant equipment by means of the runway. The hood can be removed as an individual unit.
- Engine Hatches** Removable covers are located over the engine to facilitate inspection and removal of cylinder heads, liners, pistons and other parts.
- Hood Doors** All side doors have suitable hinges and latches.
- Lifting Eyes** Four lifting eye castings are provided on the hood to facilitate handling with a crane.

SECTION 3

Trucks

GENERAL MOTORS
LOCOMOTIVES

Truck Assemblies

Two G.M. designed 4-wheel motor trucks are provided per locomotive. The truck frames are cast steel, pedestal type, with integral side frames, hollow bolster, pedestal jaws, side bearings, and center plate. Truck frames are supported on double helical and semi-elliptic springs in parallel, with provision for adjustment of height. The semi-elliptic springs on each side of the truck are supported on hangers mounted between two forged equalizers, which in turn are supported on the journal boxes.

The truck bolsters, which are cast integral with the truck frames, carry unusually large center plates with hollow center to provide for introduction of clean air from within the superstructure to the traction motors.

Four forged equalizers are provided per truck, and are machined at the journal box contacts.

Each of the four traction motors is supported in the trucks between a driving axle and a spring motor nose suspension on the truck bolster.

Axles

The axles conform to A.A.R. Specification M-126-49 Class F and ATEA recommendations for E-12-X axles.

Wheels

All wheels are rolled steel and heat treated. The contour of tread and flange conform with latest A.A.R. standards. Wheel has a diameter of 40" and width of 5½" at the tread.

Journal Boxes

Cast steel journal boxes suitable for 6½" x 12" journals are provided. Construction incorporates special G.M. end thrust arrangement.

Journal Brasses

Suitable journal bearings with deep skirt are provided.

Journal Wedges

Standard for 6½" x 12" journals.

Pedestal Liners

Spring steel of channel section welded to pedestals.

Pedestal Tie Bar

Mild steel with fitted lugs at each end, and attached to pedestals with a bolt at each end.

Side Bearings

The truck side bearings are cast integral with the frame. Special wear plates are provided.

SECTION 3

Trucks

GENERAL MOTORS
LOCOMOTIVES

Interlocks Keyed interlocks at the side bearings are provided to hold body and trucks together, and prevent sluing in case of derailment.

Center Plates Each center plate is equipped with suitable wear plates accurately machined to prevent usual center plate "slap". Truck bolster center wear plate is loose, thus permitting replacement. They are remotely lubricated from individual oil reservoirs located in carbody.

SECTION 4

Power Plant and Transmission

GENERAL MOTORS
LOCOMOTIVES

- Engine** G.M. Diesel eight (8) cylinder, 2 cycle, 8½" bore, 10" stroke, unit injection, Root's blower scavenging through cylinder wall intake, and multi-valve exhaust. Water cooled cylinder liners and heads, oil cooled pistons, five (5) bearing crankshaft, drop forged connecting rods, floating piston pin and bushing, and full floating piston assembly. Isochronous governor speed control and separate overspeed trip.
- Main Generator** EMD force ventilated, nominal 600 volt direct current generator. Single out-board bearing armature, direct connected to engine crankshaft through a flexible coupling. Capacity suitable to continuously transmit to traction motors the rated output of the engine under all conditions for which the locomotive is offered.
- Traction Motors** EMD direct current, series wound, roller bearings, force ventilated, axle hung motors.
- Auxiliary Generator** A direct current generator, provides current for control circuits, lighting, battery charging, and separate excitation of main generator. The voltage is automatically controlled by a voltage regulator.
- Load Regulator** A load regulator is provided which automatically maintains a constant horsepower output, corresponding to each throttle position.
- Engine Starting** By motoring of the main generator through use of special starting fields energized by the locomotive storage battery.
- Cooling System** Circulation system consists of direct driven centrifugal water pump; forced air circulation through fin tube radiators, and separate water supply tank. Provision made for steam heating of cooling water during layover periods. Temperature control by automatically operated shutters.
- Engine Lubricating Oil System** Dual circulation system, consisting of a pressure pump for oil delivery to the engine lubricating system, and a separate pressure pump for oil delivery to the piston cooling system, both pumps being connected to a common supply line from the oil tank. A scavenging pump delivers oil from the engine sump through the oil cooler and a four unit waste type filter to the supply sump. Pumps are protected by a strainer in the suction line. Supply sump provided with a basket strainer at the filler. Low oil pressure and high suction pressure protection is provided.
- Engine Fuel System** Return flow, with a D.C. motor driven gear pump, protected by suction filter in addition to discharge filters to insure clean fuel for the engine.

SECTION 4

Power Plant and Transmission



Engine Exhaust Single exhaust muffler.

Fuel Tank Tank built of heavy gauge steel, with baffle plates.

Capacity 600 gallons, located underneath the locomotive underframe. Filling station each side. Sump with cleanout plugs and non-removable water drains located at bottom of tank.

Full length sight glass provided on both sides of the fuel tank at the fuel filling stations.

I.C.C. Requirements Each filling station fitted with pull ring for emergency fuel cut-off. Similar pull cord is located at operator's control station.

Electrical Control Cabinet Cabinet at front of cab houses the locomotive control equipment.

Locomotive Control Automatic forward transition of motor connections between Series and Series-Parallel. Backward transition is manual between Series-Parallel and Series. A selective transition switch is provided which forestalls the automatic transition feature.

Storage Battery 32 cell, 64 volt, 284 ampere hour—(8 hour rating) battery located back of cab.

Engineer's Control Station Engineer's control station located conveniently to the left of the engineer's seat, includes the engine speed throttle, locomotive reverse lever, and transition forestalling switch. The lever arrangements are such that the throttle must be in Idle before the reverse lever can be removed to isolate the controller.

Engineer's Control Switches Multiple toggle control and lighting switches located within reach of the engineer.

Control

1. Master control
2. Generator field
3. Fuel pump
4. Engine starting
5. Cab heater

Lights

1. Headlight dim (*front*)
2. Headlight dim (*rear*)
3. Number lights
4. Gauge lights
5. Cab lights
6. Wheel-slip indicator.

Engineer's Instrument Panels Lighted instrument panels are located on the forward cab wall for:

1. Air brake gauges.
2. Engine water temperature indicators.
3. Fuel oil pressure gauge.
4. Lubricating oil pressure gauges.

SECTION 5

Air Brake Equipment

GENERAL MOTORS
LOCOMOTIVES

General The latest schedule 6-BL air brake equipment is provided, including both independent and automatic portions.

Air Reservoirs Two 22½"x84" steel reservoirs mounted beneath the underframe between the trucks, provide more than 60,000 cubic inches capacity.

Brake Cylinders Four 10"x6" double-acting cylinders of the latest type are provided per locomotive.

Brake Rigging Clasp type with two shoes per wheel.

Brake Shoes Standard A.A.R. "A-28" brake shoes provided.

Air Compressor Three cylinder, two stage, air cooled, mechanically driven by a power take-off from the main engine. This compressor has a displacement of 225 cubic feet per minute at 800 RPM of the main engine (*full power speed*), and a displacement of 77 cubic feet per minute at 275 RPM (*idling speed*). (See section 7.)

Hand Brake One staffless hand brake (52:12 ratio) is furnished and arranged for braking on one pair of wheels.

Sanding Equipment One sander valve operates eight single line sand traps, four traps for forward movement and four traps for reverse movement, thus providing sand on all eight wheels. Four sand boxes with a total capacity of 28 cubic feet are provided, thus eliminating necessity for frequent filling. All sand boxes are filled from the outside of the locomotive.

SECTION 6

Equipment

GENERAL MOTORS
LOCOMOTIVES

Cab Heater One large motor-blown hot water heater with 3-speed switch and deflectors is provided. Hot water for the heater is taken from engine cooling system.

Window Wipers Four extra heavy "Jumbo" Air Push window wipers are provided for operator's and helper's front and rear windows, giving maximum visibility under all weather conditions.

Sun Visors Four adjustable sun visors are provided, located at operator's and helper's front and rear windows.

Cab Seats Two cab seats are provided. The operator's upholstered seat is adjustable for height. An upholstered auxiliary seat serves as a cover for the tool box located next to the left side cab window. Upholstered arm rests are provided at both side windows.

Fire Extinguishers Two (2) one-gallon CTC fire extinguishers are provided, one located in the cab and one in the power plant compartment.

Tools A standard set of tools complete with portable tool box is provided.

Locomotive Lighting The full voltage locomotive lighting system provides the following number of lamps and outlets:

- a) Cab Lights, two
- b) Engine Room Lights, eight
- c) Ground Lights, two
- d) Number Lights, two
- e) Gauge Lights, four
- f) Portable Light, one
- g) Outlet Receptacles, one in cab, two in engine room

Headlights Two G.M. headlights, front and rear, are equipped with 30 volt, 200 watt sealed beam lamp and three-point dimming device. Locomotive number boxes are built integral with the headlight and independently illuminated.

Charging Receptacle One 100 ampere receptacle is provided for external charging of the battery. It is conveniently located outside the battery box at the rear of the cab.

SECTION 6

Equipment



**Warning
Signals**

Consist of:

- a) One 12" bell operated by internal pneumatic type ringer.
- b) One "Typhon" pneumatic horn, A-125-RR

**Marker and
Flag Brackets**

Four standard combination flag and light brackets are provided, two each are located at front and rear of the locomotive. All flags and oil marker and classification lights to be furnished by the railroad.

Ground Lights

One ground light on each side of locomotive under cab.

SECTION 7

Modifications



Awnings Cloth awnings over cab side windows.

Wind Deflectors Wind deflectors front and rear of side windows on each side.

SECTION 8

Painting

GENERAL MOTORS
LOCOMOTIVES

General Only the best quality materials available are used, with special attention given to both the selection of materials and methods of application to insure a maximum of protection and durability.

**Engine
Compartment** Inside finished in suede gray, trimmed in black.

**Outside
Finish** Color arrangement and design to agree with railroad's requirement.

**Under Carriage,
Trucks & Tanks** Black.

Cab Interior The cab ceiling and walls finished in green. Floor and wood trim are varnished

ELECTRO-MOTIVE DIVISION
GENERAL MOTORS CORPORATION
LA GRANGE, ILLINOIS



SPEED-TRACTIVE EFFORT CURVE
800 H. P. SWITCHER
MODEL SW-8

AUTOMATIC TRANSITION
SERIES TO SERIES PARALLEL
62:15 GEAR RATIO

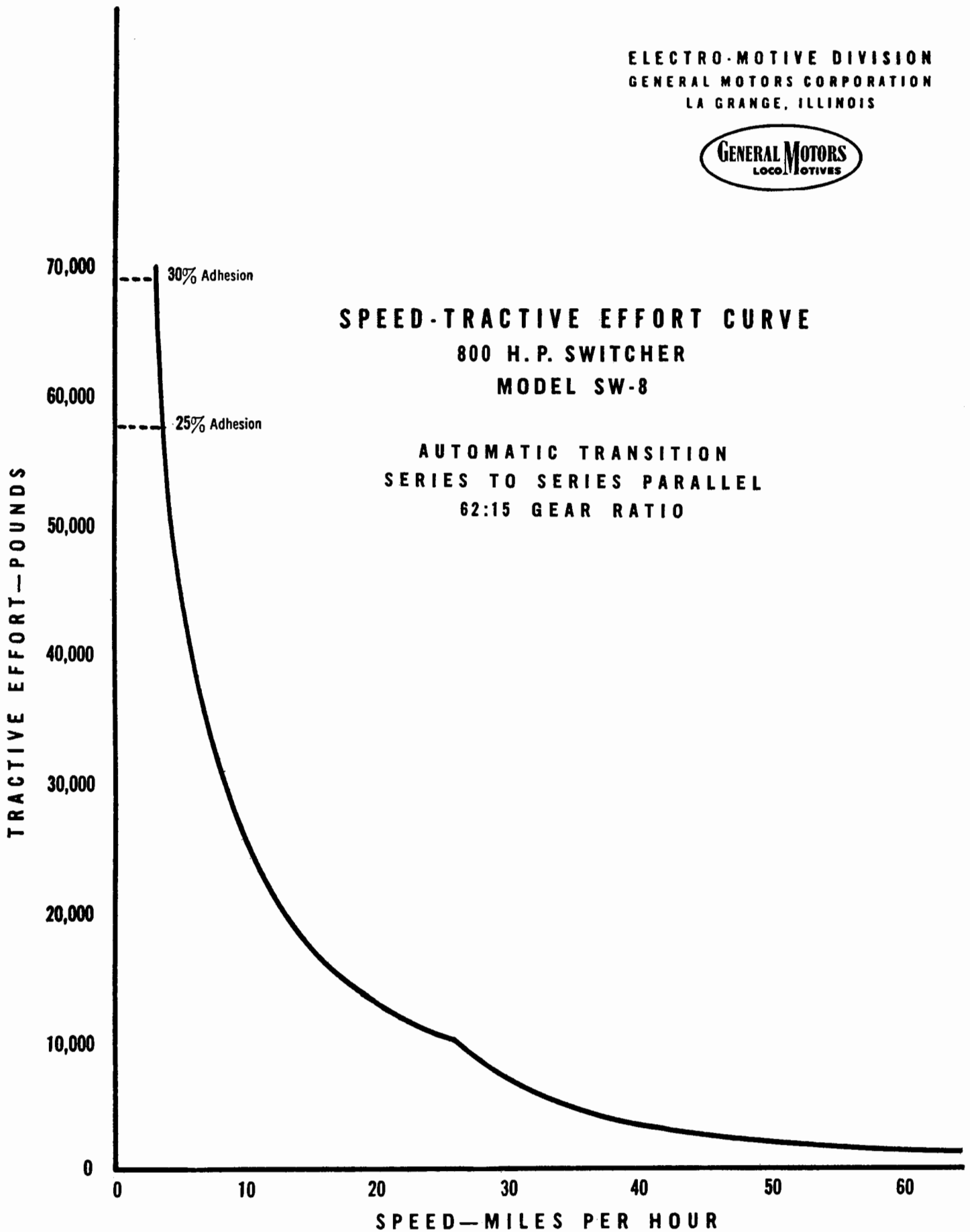

SECTION 10

Warranty and Patents

GENERAL MOTORS
LOCOMOTIVES

Warranty:

THIS IS TO CERTIFY that we, ELECTRO-MOTIVE DIVISION, GENERAL MOTORS CORPORATION, LaGrange, Illinois, warrant all new locomotives manufactured by us to be free from defects in material and workmanship under normal use and service; our obligation under this Warranty being limited to making good at our factory any part or parts thereof, which shall within one (1) year after delivery of such equipment to the original purchaser, or before the locomotives have been 100,000 miles in scheduled service, whichever event shall first occur, be returned to us with transportation charges pre-paid, and which our examination shall disclose to our satisfaction to have been thus defective.

This Warranty being expressly in lieu of all other Warranties expressed or implied and of all other obligations or liabilities on our part, and we neither assume nor authorize any person to assume for us any other liability in connection with the sale of our equipment.

This Warranty shall not apply to any locomotive components which shall have been repaired or altered unless repaired or altered by us or by our authorized service representatives, if, in our judgment, such repairs or alterations affect the stability or reliability of the equipment, or if the equipment has been subject to misuse, negligence or accident.

We reserve the right to make changes in design or add any improvements on equipment at any time without incurring any obligation to install same on equipment previously purchased.

Patents:

The Electro-Motive Division, General Motors Corporation, will not assume liability for patent infringement by reason of purchase, manufacture, sale, or use of devices or equipment not included in and covered by this Specification.



ELECTRO-MOTIVE DIVISION
GENERAL MOTORS CORPORATION
LA GRANGE, ILLINOIS

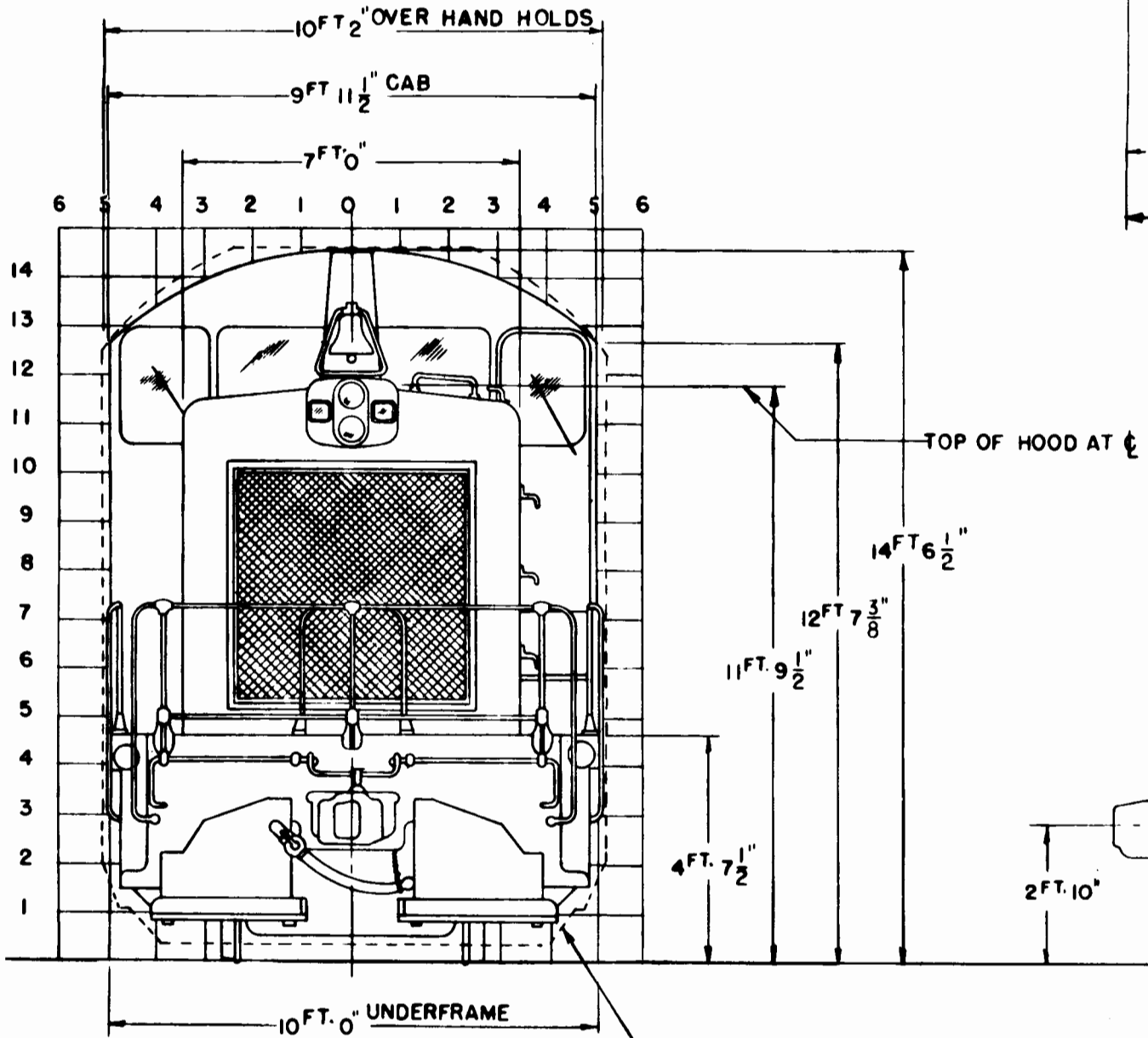

A.A.R. CLEARANCE DIAGRAM (UNRESTRICTED)

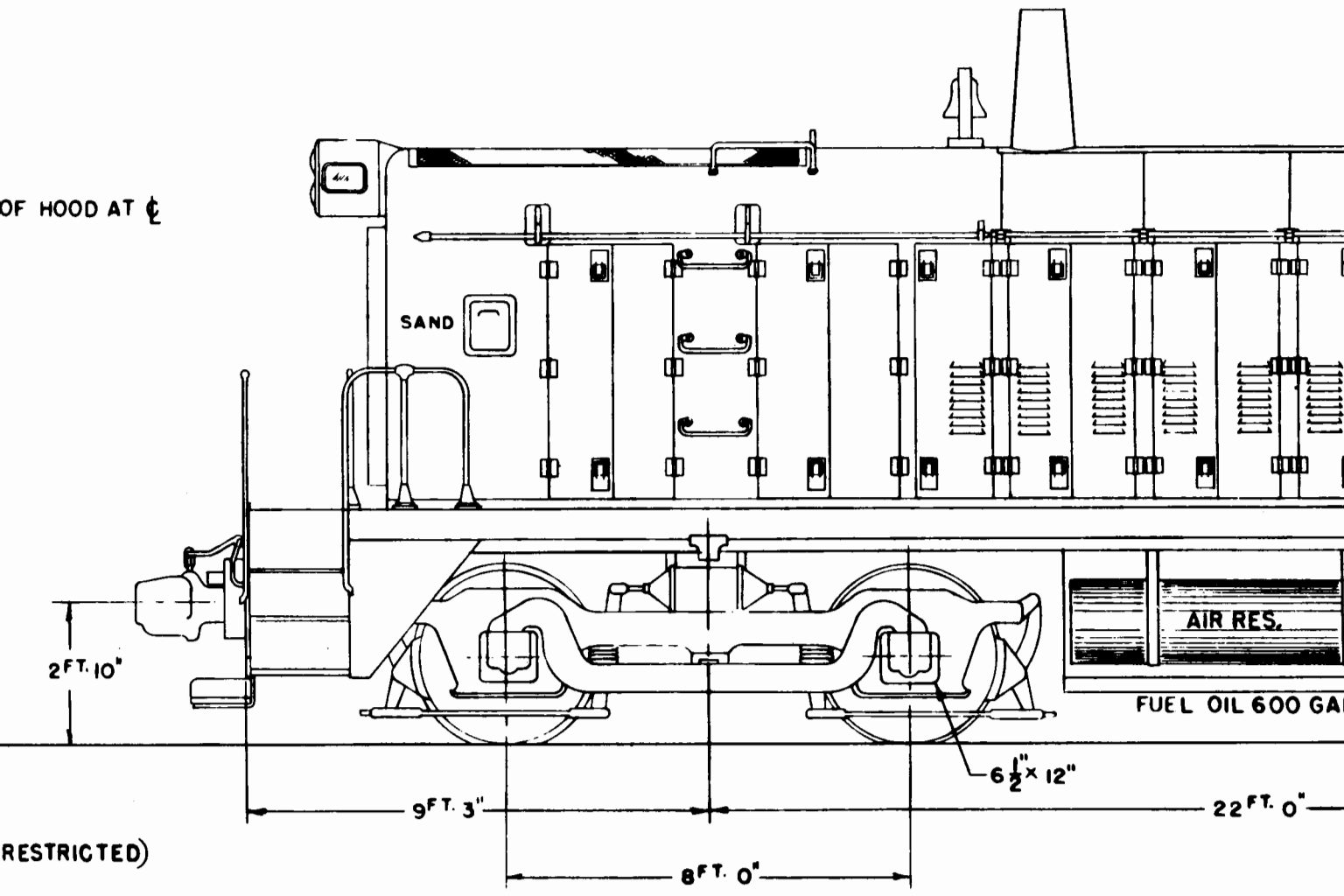
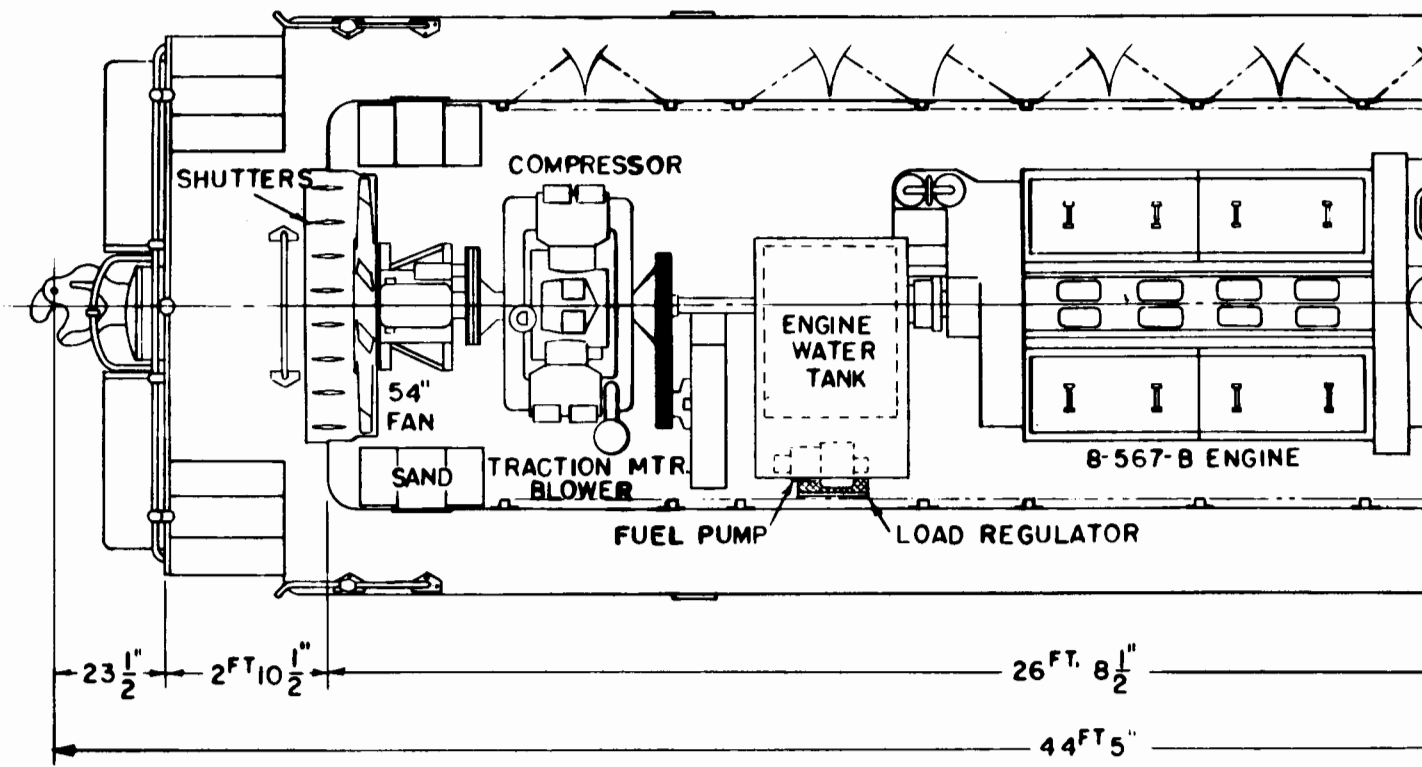

800 H. P. SWITCHING LOCOMO

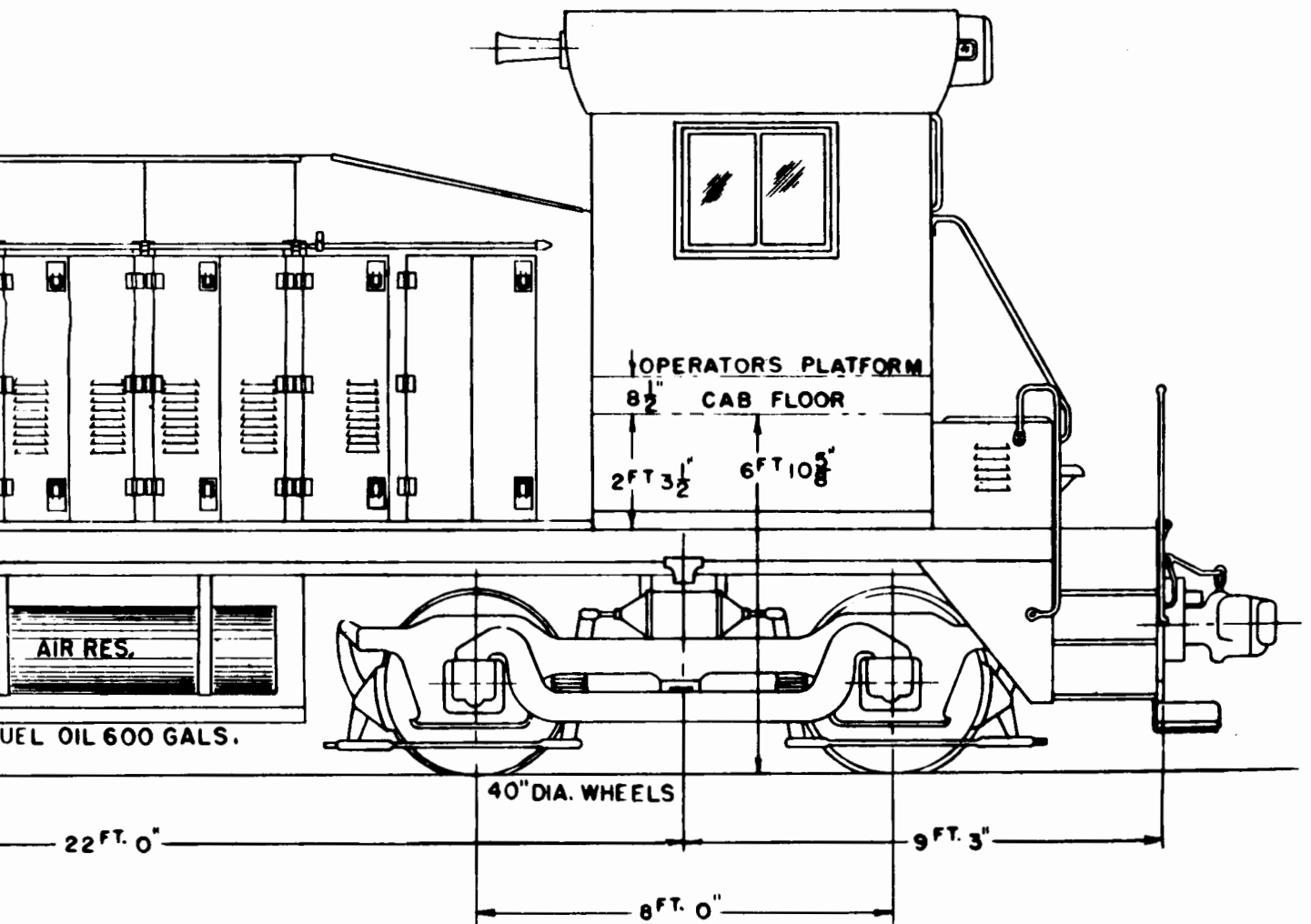
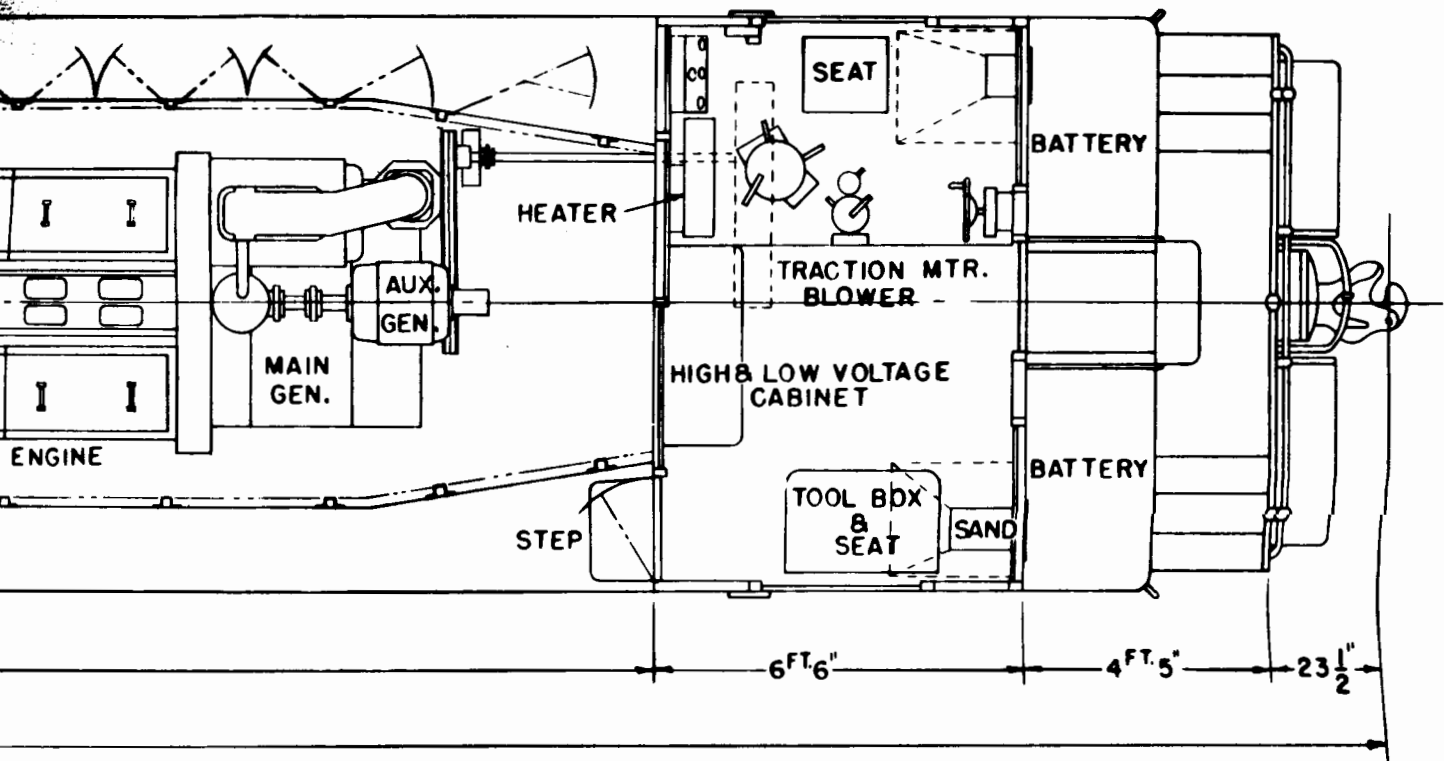

LOCOMOTIVE • MODEL SW-8